

DESCRIPTION

Sanland's SG204 is a GaAs pHEMT single ended MMIC RF amplifier IC featuring 22dB of gain and low noise. This high linearity IC is designed to support DOCSIS 4.0 Amplifiers and Nodes, as well as Fiber to The Home (FTTH), Satellite, Terrestrial TV, Home Gateways, and Cable Modems applications from 50 to 1800MHz. The SG204 is powered by a single 5V supply and packaged in 3 x 3 QFN.

Major Applications

- DOCSIS 4.0 Amplifiers
- DOCSIS 4.0 Optical Nodes
- DOCSIS 4.0 Remote PHY Devices
- FTTH GPON and GEPON
- DOCSIS 4.0 Cable Modem and Home Gateways
- Single Ended Gain Block

KEY FEATURES

- 50 MHz to 1800 MHz Operation
- 5 V Operation
- Gain: 22.4 dB Typical
- P1dB: 21dBm
- OIP3: 38dBm
- Noise Figure: 1.7 dB @1800MHz
- RoHS Compliant

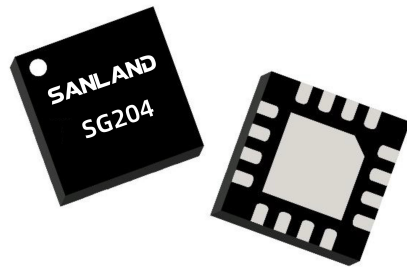

Pin Assignment

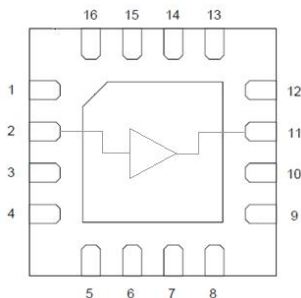

Pin Details

Pin	Name	Function
2	RF in	RF Input
11	RF out	RF Output/Bias
1,3,4,5,6,7,8,9,10,12,13,14,15,16	GND	Ground

Absolute Maximum Ratings

Parameter	Rating	Unit
Supply Voltage (VDD)	+10	V
Supply Current (I _{DD})	170	mA
Maximum RF Input Level	+60	dBmV
Operating Ambient Temperature	-40~100	°C
Storage Temperature	-65~150	°C
Max. Junction Temp. (T _J)	+150	°C

Important Note:

The information provided in this datasheet is deemed to be accurate and reliable only at present time. Sanland Technology Corp. reserves the right to make any changes to the specifications in this datasheet without prior notice.



Caution: ESD Sensitive
Appropriate precaution in handling, packaging
And testing devices must be observed.

Electrical Specifications at +5 V

Temp = +25 ° C, VDD = +5V, 75Ω system, Full band unless otherwise noted

Parameter	Specification			Unit	Notes
	Min	Typ.	Max		
Frequency	50	-	1800	MHz	
Supply Voltage (VDD)		5		V	
Supply Current (IDD)		125		mA	
Gain		22.4		dB	
Gain Slope		0.2		dB	
Reverse Isolation		25		dB	
Input return loss	15	18		dB	
Output return loss	15	20		dB	
MER		-		dB	At +57dBmV Total Composite Output power. 108MHz to 1791MHz, 280Ch, SC-QAM, 0dB tilt, 0dB offset
Noise Figure		1.7		dB	
OIP2L		65		dBm	Tone Spacing=50MHz F1=400MHz, F2=450MHz, +5dBm / tone output
OIP2U		60		dBm	
OIP3	34	38		dBm	Tone Spacing=1MHz, +5dBm / tone output
OP1dB	18	21		dBm	
Thermal Resistance		57		°C/W	

Application Circuit

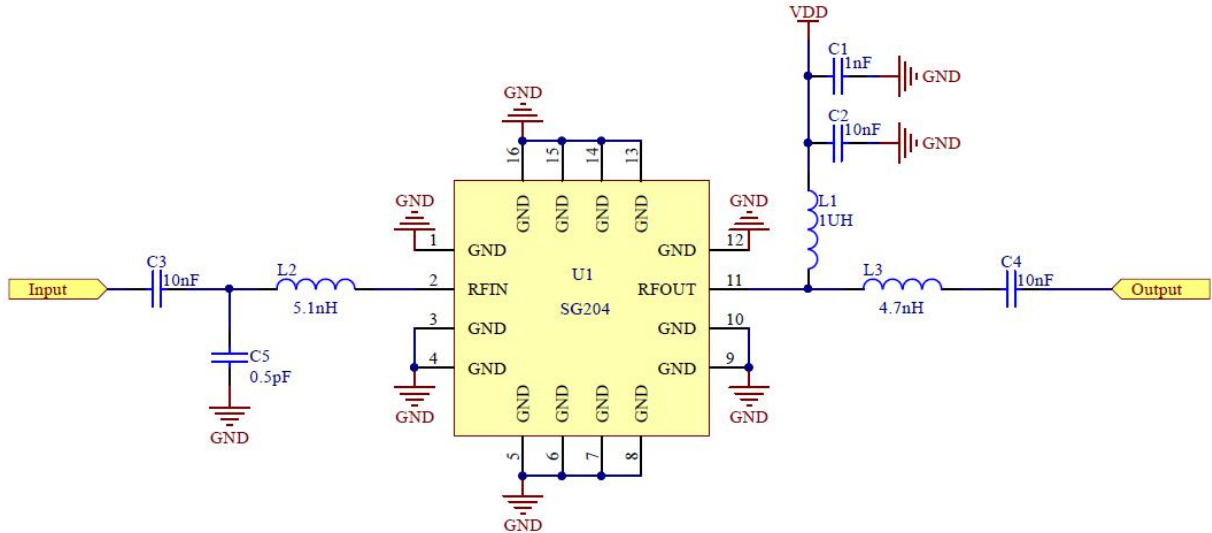

Component	Value	Size	Vendor	Part Number
U1	-	-	SANLAND	SG204
PCB	-	-	SANLAND	-
C1	1nF	0402	MURATA	GRM1555C1H102JA01D
C2,C3,C4	10nF	0402	MURATA	GRM1555C1E103JE01D
C5	0.5pF	0402	MURATA	GRM1555C1HR50CA01D
L1	1uH	0603	FH	FHW0603UF1R0JST
L2	5.1nH	0402	MURATA	LQG15HS5N1S02D
L3	4.7nH	0402	MURATA	LQG15HS4N7S02D

Evaluation Board Assembly Drawing

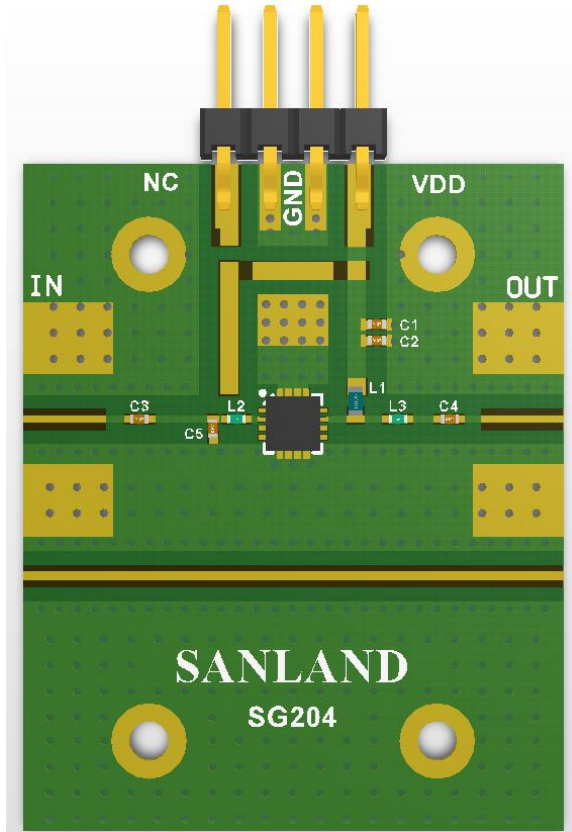

Performance Data at +5V

(VDD = +5V, Temp = +25C, Zo = 75Ω)

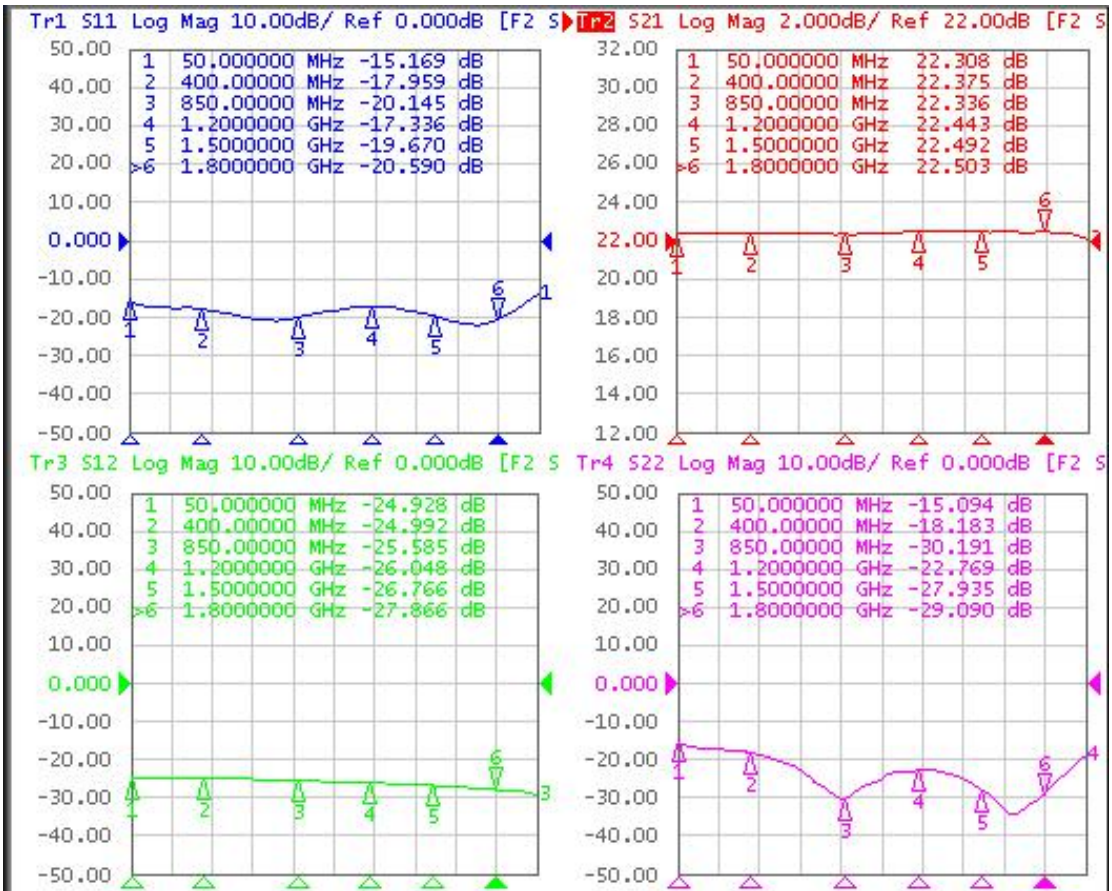

Performance Data at +5V

(VDD = +5V, Temp = +25C, Zo = 75Ω)

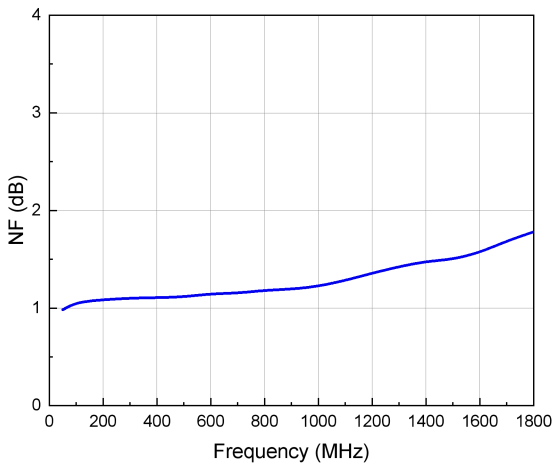
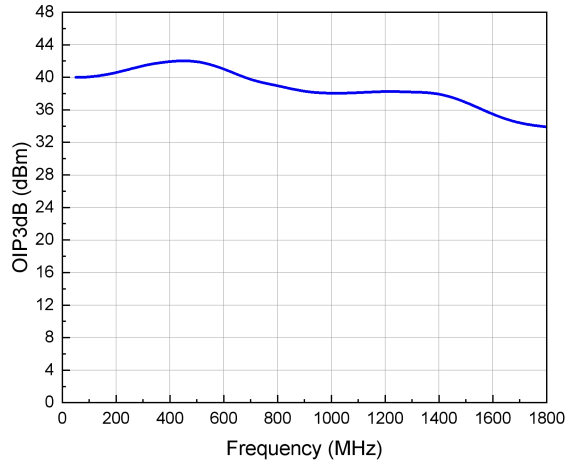
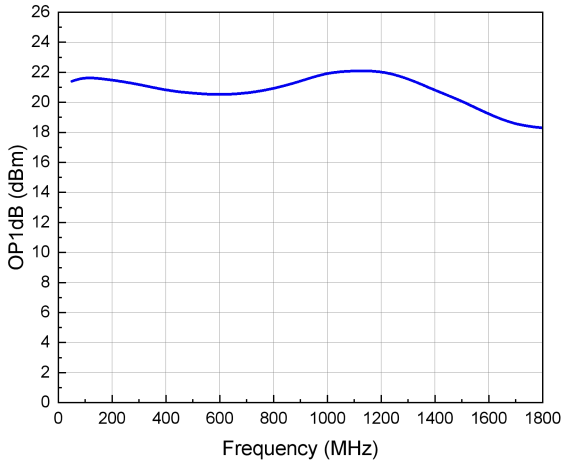

Note:

(1) OIP3: +5dBm / tone output

Package Outline

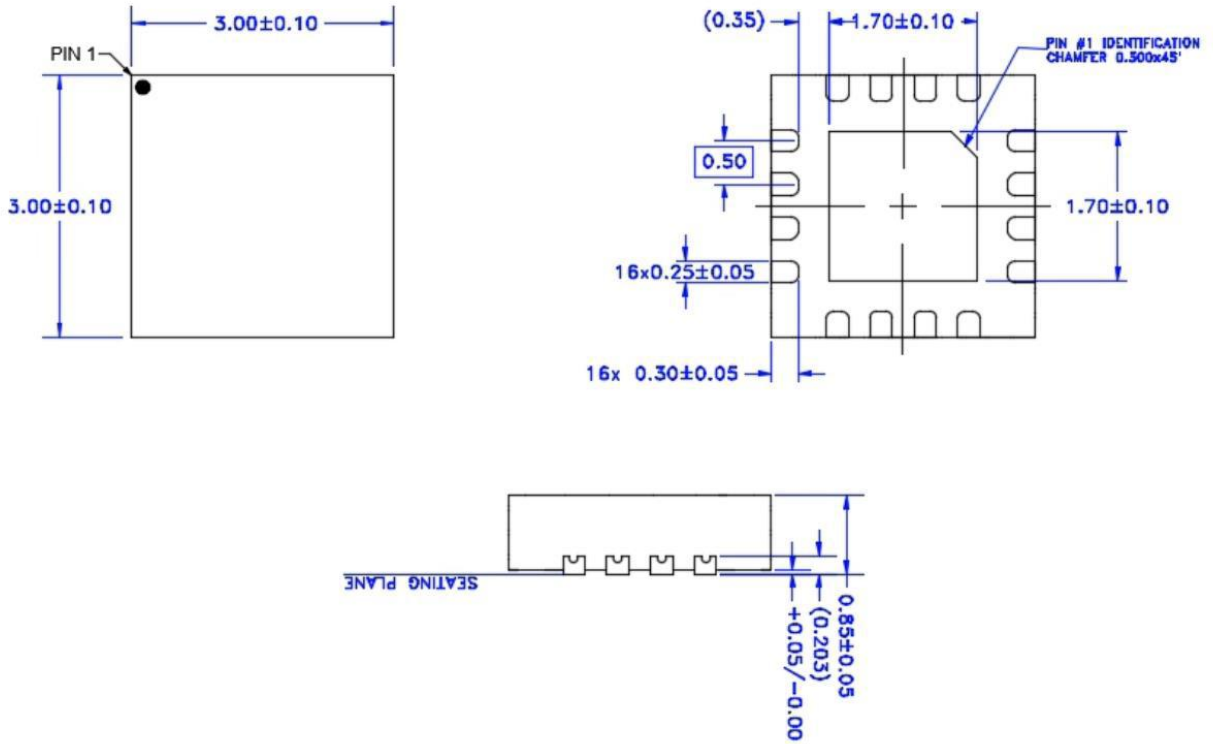

3 x 3 16-pin QFN

Recommended Mounting Pattern

